

Drawing #: 60222-W-10 Rev 2
 60222 Monitor Arm Configuration, Wall Mounted w/ 10" Extension Arm, Combination #2

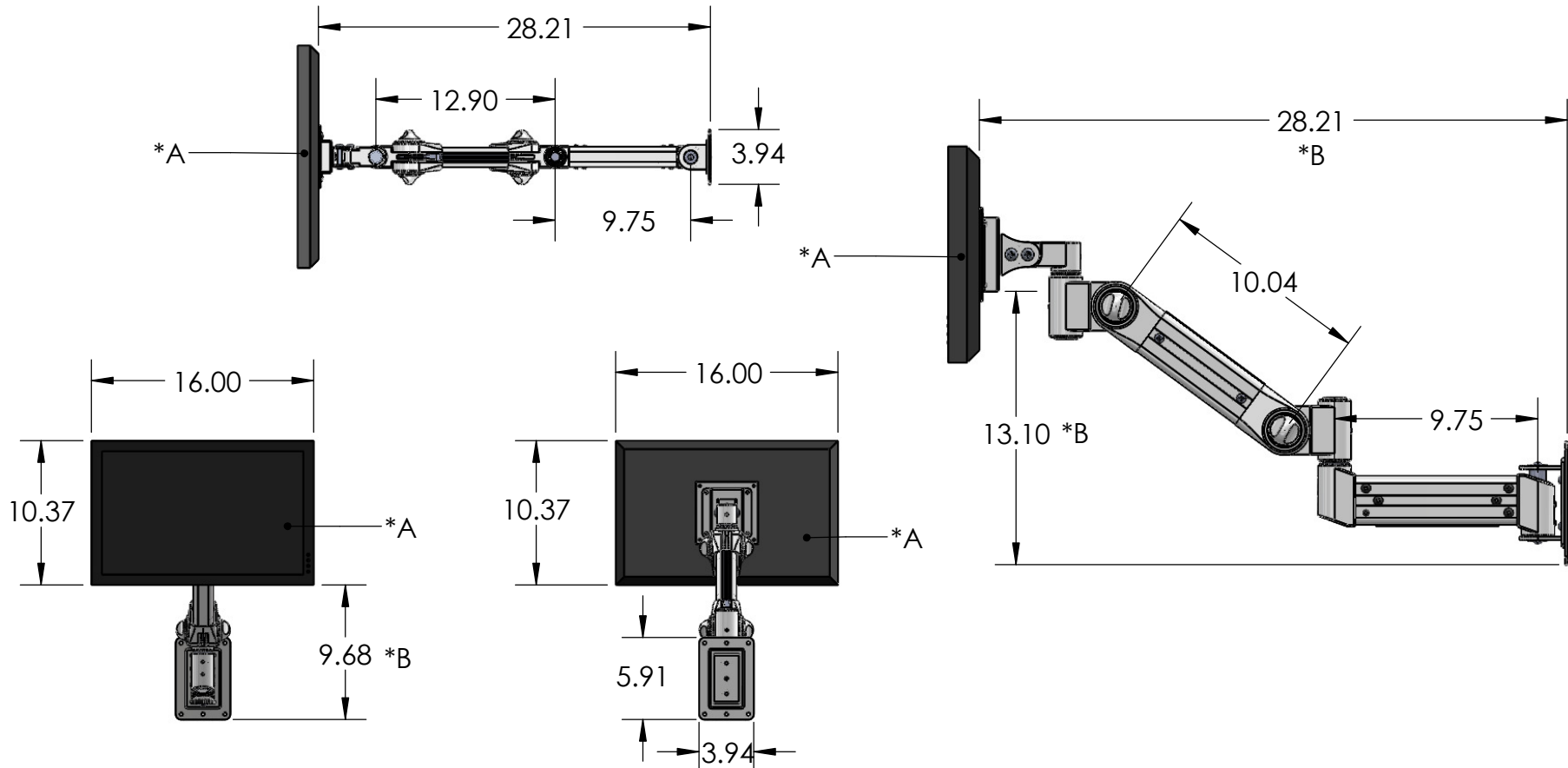

*A: Monitor is shown for drawin purposes only. Customer's monitor size may vary from the drawing. Monitor NOT included in assembly
 *B: Adjustable arm shown at 45 degrees. Arm can be adjusted from horizontal to vertical. Some dimensions may change as the arm moves

PROPRIETARY AND CONFIDENTIAL
 THE INFORMATION CONTAINED IN THIS DRAWING IS THE SOLE PROPERTY OF CUSTOM PRODUCTS AND SERVICES. ANY REPRODUCTION IN PART OR AS A WHOLE WITHOUT THE WRITTEN PERMISSION OF CUSTOM PRODUCTS AND SERVICES IS PROHIBITED.

		UNLESS OTHERWISE SPECIFIED:		NAME	DATE				
		DIMENSIONS ARE IN INCHES		DRAWN	NJN	12/20/13	TITLE: 60222 with 10" Extension Arm		
		TOLERANCES:		CHECKED					
		FRACTIONAL ±		ENG APPR.					
		ANGULAR: MACH ± BEND ±		MFG APPR.					
		TWO PLACE DECIMAL ±		Q.A.			COMMENTS:		
		THREE PLACE DECIMAL ±							
		INTERPRET GEOMETRIC TOLERANCING PER:					SIZE	DWG. NO.	REV
		MATERIAL					A	60222-W-10	2
		FINISH							
NEXT ASSY	USED ON						SCALE: 1:12	WEIGHT:	SHEET 1 OF 1
APPLICATION		DO NOT SCALE DRAWING							